

NOISE REDUCTION OF CENTRIFUGAL FAN BY USE OF RESONATOR AND ACTIVE NOISE CONTROL TECHNIQUE

PATIL T. B¹, BOROLE K. R² & SANAP S. B³

¹Research Scholar, Sinhgad College of Engineering, University of Pune, Maharashtra, India

²Professor, Smt. Kashibai Navale College of Engineering, University of Pune, Maharashtra, India

³Associate Professor, Sinhgad College of Engineering, University of Pune, Maharashtra, India

ABSTRACT

Centrifugal fans are extensively used in industrial applications and there is a continual and increasing demand for higher flow rate machines with the attendant restriction of the smallest possible dimensions. This increase in flow rate is normally achieved by the use of higher speeds and which leads to increase in the noise generation mechanism within the fan unit, resulting in the radiation of extremely objectionable high frequency discrete tones. Noise causes nuisance and hazard to hearing. The noise generated by centrifugal fan contains tonal as well as random components. Blade tones are generally the most annoying components and need to be reduced. The production of the tone is known to originate from within a concentrated region around the cut-off of the fan casing. The tone is produced by the interaction of the mean air flow leaving the impeller with the asymmetric part of the casing comprising the cut off. At present little attention is given towards the noise generated by the centrifugal fans. The conventional method of treatment is to use passive damping techniques or to redesign the fan. Redesign is often costly and ineffective. In the last decade, resonators and active noise control technique have emerged as a viable technology to reduce the noise levels of centrifugal fans. The level of blade passing frequency component can be reduced substantially by mounting acoustic quarter-wavelength resonators into the cut off which is made of perforated sheet metal to permit communication of the resonator cavities with the interior of the fan casing.

KEYWORDS: Centrifugal Fan, Cut-Off, Noise, Quarter - Wavelength Resonator

INTRODUCTION

Noise is an unwanted sound, which can be described as rapid pulsations in air pressure produced by a vibrating source. The effects of noise range from annoyance, fatigue and reduced comfort, to safety and even health hazards like hearing loss, changes in the electrical activity of the brain and changes in the heart and respiration rate. Noise masking impairs the speech communication resulting in inefficiency and more seriously can result in accidents. Warning bells on machinery, hooters on factory, trucks or even motor cars, shouted warnings etc., can be missed because of their submergence in the overall noise. On machines the effect may be wear, reduced performance, faulty operation or degree of irreversible damage. Hence the reduction in the machinery noise has become very important field of study in the present industrial environment. The applications and use of fans, blowers today are universal. A fan is a low pressure producing machine. A blower which is also sometimes referred to as a fan develops an appreciable rise in pressure of the gas flowing through it. The industries in which these machines are used include chemical, petroleum, textile, paper, food, power, cement, sugar and air conditioning systems etc. High draft fans in mines, cooling tower fans, induced draft and forced draft fans for steam boilers used in various industries are some examples of centrifugal type fans and blowers. Thus fans and blowers are essential and important machines in large number of industries.

Despite their obvious merits centrifugal fans have one important drawback- the high level of air noise which can reach 90-130 dB. They are major sources of noise in industry. It is necessary to control the industrial noise not only to ensure proper operation of machinery but to provide adequate protection to workers and to maintain proper environment to comply with the law. Noise is generally acceptable up to certain levels.

Whatever the individual design, centrifugal blowers may all be described by reference to Figure 1. The fluid enters the impeller near its center while moving parallel to its axis of rotation between the blades of the impeller (which may curve forward or backwards with respect to planes containing the axis of rotation or coincide with them).

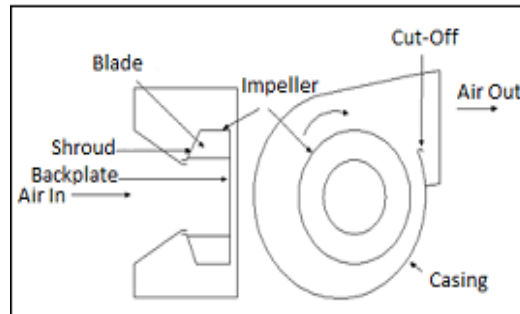

Figure1: Schematic of Centrifugal Fan

The fluid is forced to the periphery and ejected into the volute. The outlet is separated from the beginning of the volute by the cut-off, which is usually the point of closest approach between moving and stationary members. In some blowers, the impeller is surrounded by a ring of diffuser blades, acoustically, these may be considered as a number of identical cut-offs. The only working fluid studied here is air.

Sounds originating within the blowers are of two main types – (1) aerodynamic noise and (2) non-aerodynamic noise. In so far as aerodynamic noise is concerned, it comprises of two components, viz. [1] the rotational component and [2] broad band noise. The flow is not uniform around the periphery of the impeller and, consequently, there is radiation at the frequency with which blades pass any given fixed point and also at the harmonics of this frequency known as the rotational component. In addition to this line spectrum, there is broad-band noise generated in the flow by aerodynamic processes.

From subjective point of view, the blade passage tone is generally the most annoying component and thus needs to be reduced. Also, the production of the tone is known to originate from within a concentrated region around the cut-off of the fan casing. This feature makes the prospect for altering the tone generating mechanism directly at the source an attractive possibility.

A simple and reliable method of reducing the noise of fans has been evaluated and this does not require any increase in weight, overall dimensions or any substantial modification to the fans. The effectiveness of this method can be assessed by the fact that it is possible to reduce the overall level of air noise to approximately 4-9 dB, and to reduce the spectral noise level to approximately 6-11 dB.

LITERATURE REVIEW

Reduction of the Generated Sound by Modifying the Fan Itself

In conventional centrifugal fan design, the cut-off edge and trailing edges of the blades are parallel to one another. The pressures along the cut-off which are excited by the flow are in phase. When either the cut-off or the blades or both are inclined, a phase shift of the pressure is introduced, which results in local cancellation and hence lower sound radiation into the acoustic far-field.

Embleton^[4] measured properties of two double inlet impellers. In most blowers, the tips of the impeller blades and the edge of the cutwater are parallel to each other thus, the blades excite all points along the edge with the same phase and the localized sound source has its maximum strength. This may be reduced by placing the blade tips and the edge of the cutwater at an angle to each other, this angle lying in a surface roughly tangential to the periphery of the impeller. Either or both the blades and cutwater may be sloped in order to achieve the desired angle, but sloping of the impeller blades has an influence on most parameters of the blower while sloping of the cutwater affects only the strength of the noise source. Therefore, advantageous to slope the impeller blades by the amount necessary to optimize the operating conditions of the blower and in conjunction to slope the cutwater in order to minimize the strength of the noise source as shown in figure 2.

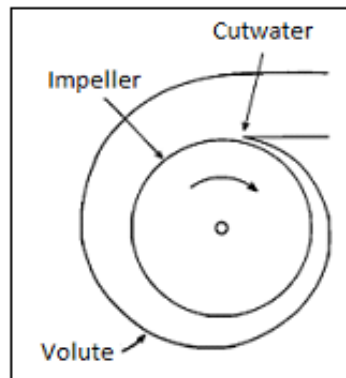

Figure 2: Schematic Diagram of any Centrifugal Blower

Sloping the cutwater is not new, the cutting edge at an angle to the face of the fan blade, we can get rid of the objectionable noise and vibration. A single long incline, or two inclines meeting at the center, give good results. The slope should encompass at least the distance between impeller blades. The present work indicates that this is sufficient to obtain the maximum noise reduction and that some reduction may be obtained with slopes only one half or one third as great. At small clearances, when the blade frequency is strongly emitted, one may reduce the sound output by 10 or 12 dB, using a slope extending over one space between impeller blades. When such an angle exists there is no minimum of sound pressure level, as radial clearance between the impeller and the stator is varied, the sound pressure level drops progressively as the clearance is increased. The effect on the sound pressure level of increasing the clearance and sloping the cutwater are additive.

The Use of Resonators to Silence Centrifugal Blowers

G.H.Koopmann and W.Neise^[6] investigated the noise of centrifugal blower could be reduced significantly by replacing the cut-off of the scroll with the mouth of a quarter wavelength resonator. To preserve geometry, the mouth of the resonator, which was formed from a perforated plate. Tuning of the resonator was achieved by changing the length of the cavity via a movable end plug. When the resonator was tuned appropriately, reduction in blade passing frequency tones up to 29 dB and corresponding overall sound pressure level reductions up to 7 dB as the blowers operating under different acoustic and aerodynamic loading in both outlet and inlet ducts.

The tone intensity reduced with the use of a quarter wavelength tube resonator, the mouth of which forms the cut-off of the centrifugal blower. If the resonator is tuned to the blade passing frequency or its harmonics, the pressure generated by the flow at the cut-off region at this frequency are substantially reduced. The addition of the resonator does not require significantly more space. The geometry of neither the cut-off nor the fan casing is altered, the aerodynamic performance is unaffected.

The cut-off of the blower casing scroll was modified for achieving the maxima for the levels of noise reduction with the addition of resonator. The blade passing frequency component strongly predominant within the noise spectrum. The level of blade passing frequency component is inversely proportional to the cut-off clearance, the type of noise spectrum was obtained by positioning the resonator mouth sufficiently near the impeller^[6].

W. Neise^[3] studied the level of blade passing frequency component reduced due to the presence of resonator. When all the perforate sections are open, the resonator behaviour as a function of the aerodynamic loading conditions. The mechanism by which the resonator acts to reduce the pressure fluctuations generated by the cut-off or blade interactions, the maximum reduction occur at different frequencies.

The cavity of the resonator consists rectangular ducts which are terminated with adjustable end plugs, resonator to the side of the impeller indicated that its presence had little effect on the noise reduction mechanism. The substantial noise reduction observed at a frequency which quarter wavelength corresponds nearly to the length of the resonator, the extent of noise reduction that an optimum resonator impedance exists for a given flow conditions at a particular frequency.

METHODOLOGY

Design of Quarter Wavelength Resonator

The cross sectional area of the resonator is rectangular with its longest lateral dimensions (width) being equal to the width of the fan casing. The mouth of the resonator is perforated over entire width of the casing. The width of the resonator is 110 mm and the height of the resonator is 20 mm. The resonator is designed to give resonant frequency of 420 Hz which is the blade passing frequency of the fan. For this, it is required to calculate the length of the resonator.

$$f = \left(\frac{kc}{4L} \right) Hz \quad (1)$$

Where, c = Speed of sound in air i.e. = 343 m/s

$$K = 1, 3, 5, \dots$$

$$L = \text{Length of the resonator (m)}$$

Substituting the values of f , c and K in equation 1 we get the length of the resonator.

$$420 = (1 \times 343) / (4L)$$

$$L = 0.204 \text{ m}$$

The rate perforation is changed at the resonator mouth by changing the hole diameter for various designs of the $\lambda/4$ resonators. The table 1 below gives the details of the 5 types of $\lambda/4$ resonators.

The sheet metal is used for the fabrication of resonators. The photograph of the resonator is shown in figure 3 (a). The development drawing with dimensions is marked on the sheet metal. Then it is cut by the scissors. Then perforates are made at the proper place of cut portion of a sheet metal by using laser cutting machine. The five designs of the resonator to make perforations i.e. 2.7 mm, 3.0 mm, 3.5 mm, 3.7 mm and 4 mm. Then by using bending machine, the cross section of the resonator is made rectangular. The mouth portion of the resonator is made in circular arc portion by using the hammer. Then the soldering is done. To change the resonator length, the wooden piece having rectangular cross section which formed an air tight seal with the resonator walls is fabricated. shows the details of the quarter wavelength resonator used for the noise reduction of centrifugal fan. shows the five types of resonators used for the noise reduction of centrifugal fan.

EXPERIMENTAL SETUP

The experimental work involves measurements of overall noise level and its analysis in frequency domain. These aspects of experimental work are briefly described below. Sometimes, only the overall magnitude (rms or peak) of a signal is of any real concern to a maintenance engineer. Prior research and experience with the performance of the particular piece of machinery often provide sufficient guidelines to allow for the establishment of “go” and “no go” confidence levels. Some simple examples include the allowable peak sound pressure level due to some impact process or the allowable rms overall noise level due to some continuous noise source, it is also quite common for rms peak noise levels at various locations to be continuously monitored. When the allowable levels are exceeded, the respective components are inspected and serviced etc. It is common practice for the overall magnitude of a noise signal to be monitored continuously. Signal magnitude analysis thus involves the monitoring and analysis of parameters such as mean signal levels, mean-square and rms signal levels, peak signal levels. Another very important application of signal magnitude analysis is a study of the distribution of peak or extreme values of discrete events. The sound pressure level (often abbreviated to SPL) measured at any points depends on the acoustic power output of a noise source, the distance from the source to the measuring point, and the environment in which the noise source and measurement point are placed. The units used are decibels (dB).

Sound is often measured in conjunction with a problem related to human hearing. The loudness of the pure tones, perceived by the ear, varies not only with the frequency but also with the intensity level. The ear is comparatively insensitive at the lower frequencies so that, for equivalent loudness, a much higher intensity is required at the low frequencies than at the medium frequencies. We have also observed that the difference in intensity is required, for equivalent loudness, is gradually reduced with higher intensity levels, and when we reach a level of about 80 dB and above, the ear is equally sensitive at the low and the medium frequencies. In order to obtain a correct idea of the effect of noise on ear, we need to use suitable frequency ‘weighing networks’.

We should use network marked –

- A for sound levels below 55 dB
- C for sound levels above 85 dB

Experimental Work

Figures 3 (a) and (b) show the schematic arrangement of the test facility developed for the experiment. The fan used for the experimental study was 9 bladed, 0.75 kw, 2800 rpm. Throughout the experiment, the fan was run at a rated speed of 2800rpm, 2700rpm, 2600rpm, 2500rpm, and 2000rpm by a 0.75 kw motor.



Figure 3 (a): Photograph of Setup with Resonator

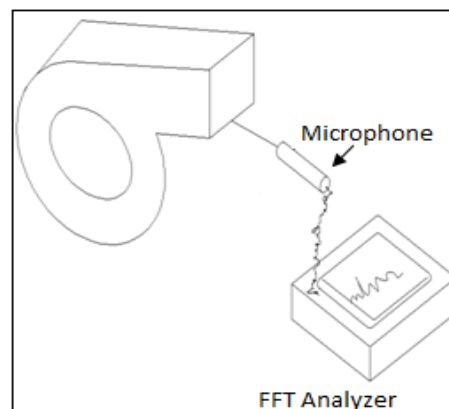

Figure 3 (b): Schematic Arrangement of Test

Table 2 gives the details of overall noise level and blade passing frequency for the original fan running at 2800 rpm, 2700 rpm, 2600 rpm, 2500 rpm, 2000 rpm.

Table 1: Details of Quarter Wavelength Resonator

Type	Hole Diameter in mm	Number of Holes	% Perforation Open Area Proportion	Width of the Resonator in mm	Height of the Resonator in mm	Length of the Resonator in mm
1	2.7	63	16.39	110	20	204
2	3.0	63	20.24	110	20	204
3	3.5	36	27.55	110	20	204
4	3.7	63	30.79	110	20	204
5	4	63	35.98	110	20	204

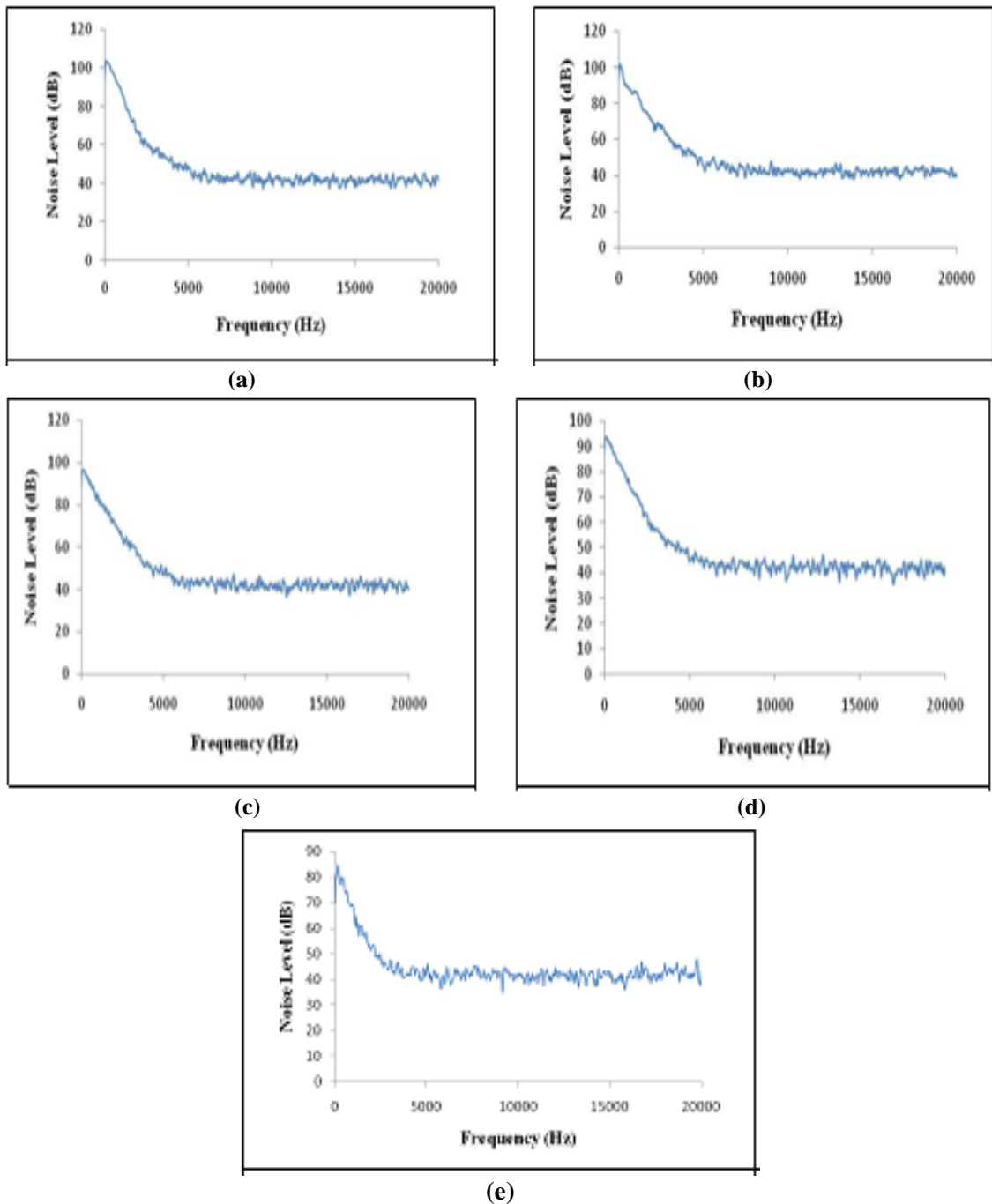

Figure 4: (a), (b), (c), (d), (e) Gives the Noise Level and Peak List Point for the Original Fan Running at 2800 rpm, 2700 rpm, 2600 rpm, 2500 rpm and 2000 Rpm

Table 3 gives the details of quarter wavelength resonator.

Table 2: Overall Noise Level and Blade Passing Frequency Level for the Original Fan

Rpm	Overall Noise Level dB(C)	Blade Passing Frequency Tone 420 Hz dB(C)
2800	110.4	101.4
2700	106.5	90.45
2600	103.9	92.5
2500	101.4	90.1
2000	89.0	79.0

Table 3: Details of Quarter Wavelength Resonator

Type	Hole Diameter	Number of Holes	% Perforation Open Area Proportion
Quarter Wavelength Resonator (1)	3.5 mm	63	27.55%
Quarter Wavelength Resonator (2)	3.7 mm	63	30.79%
Quarter Wavelength Resonator (3)	4.0 mm	63	35.98%

RESULTS AND DISCUSSIONS

Comparison Result of Quarter Wavelength Resonator with Original Fan

Figure 5 (a), (b), (c), (d), (e) shows the overall noise level and blade passing frequency component of resonator 1 of 3.5 mm hole diameter and total number of 63 holes for the fan running at 2800 rpm, 2700 rpm, 2600 rpm, 2500 rpm and 2000 rpm.

Table 3 gives the details of reduction in overall noise level and blade passing frequency level for the resonator 1 running at 2800rpm, 2700rpm, 2600rpm, 2500rpm, 2000rpm.

Figure 6 (a), (b), (c), (d), (e) shows the overall noise level and blade passing frequency component of resonator 2 of 3.7 mm hole diameter and total number of 63 holes for the fan running at 2800rpm, 2700rpm, 2600rpm, 2500rpm and 2000rpm.

Table 4 gives the details of reduction in overall noise level and blade passing frequency level for the resonator 2 running at 2800rpm, 2700rpm, 2600rpm, 2500rpm, 2000rpm.

Figure 7 (a), (b), (c), (d), (e) shows the overall noise level and blade passing frequency component of resonator 3 of 4.0 mm hole diameter and total number of 63 holes for the fan running at 2800rpm, 2700rpm, 2600rpm, 2500rpm and 2000rpm.

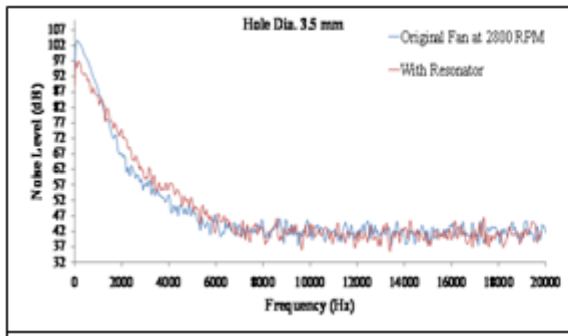

Figure 5 (a): Overall Noise Level and Blade Passing Frequency Component of Resonator 1 of 3.5 mm Hole Diameter and Total Number of 63 Holes for the Fan Running at 2800rpm

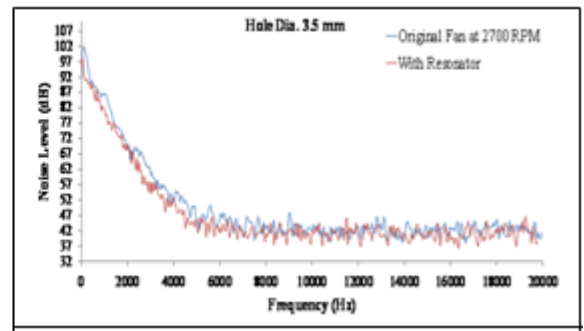

Figure 5 (b): Overall Noise Level and Blade Passing Frequency Component of Resonator 1 of 3.5 mm Hole Diameter and Total Number of 63 Holes for the Fan Running at 2700rpm

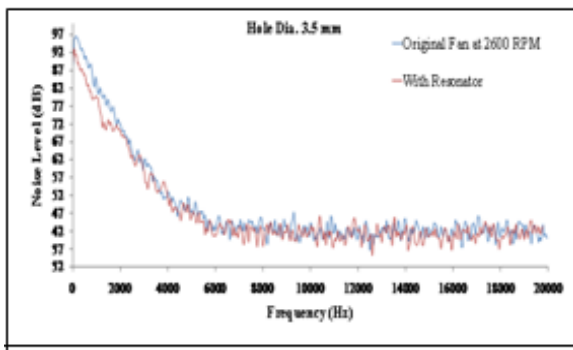

Figure 5 (c): Overall Noise Level and Blade Passing Frequency Component of Resonator 1 of 3.5 mm Hole Diameter and Total Number of 63 Holes for the Fan Running at 2600rpm

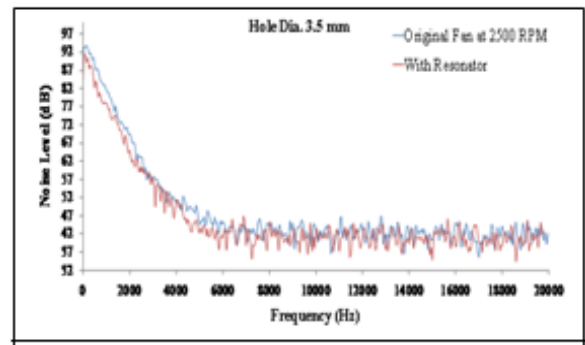

Figure 5 (d): Overall Noise Level and Blade Passing Frequency Component of Resonator 1 of 3.5 mm Hole Diameter and Total Number of 63 Holes for the Fan Running at 2500rpm

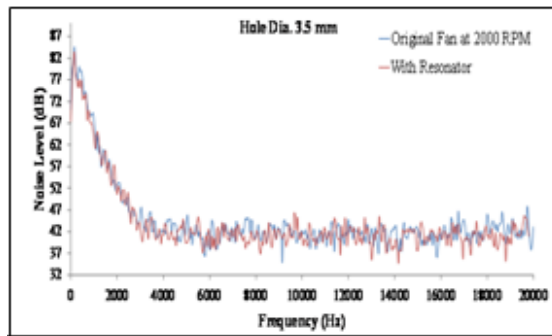

Figure 5 (e): Overall Noise Level and Blade Passing Frequency Component of Resonator 1 of 3.5 mm Hole Diameter and Total Number of 63 Holes for the Fan Running at 2000rpm

Table 4: Reduction in Overall Noise Level and Blade Passing Frequency Level for the Resonator 1

Rpm	% Perforation Open Area Proportion	Reduction in Overall Noise Level dB (C)	Noise Reduction at Blade Passing Frequency Tone dB (C)
2800	27.55%	6.2	8.7
2700	27.55%	4.2	1.5
2600	27.55%	4.9	5.9
2500	27.55%	3.5	4.2
2000	27.55%	1.7	3.0

Table 5 Gives the Details of Reduction in Overall Noise Level and Blade Passing Frequency Level for the Resonator 3 Running at 2800rpm, 2700rpm, 2600rpm, 2500rpm, 2000rpm.

The reduction in overall noise level and blade passing frequency level for the resonator 1, 2, 3 when the fan running at 2800rpm as shown in table 6.

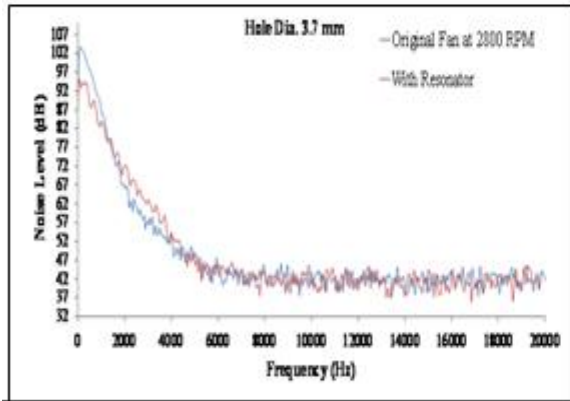

Figure 6 (a): Overall Noise Level and Blade Passing Frequency Component of Resonator 2 of 3.7 mm Hole Diameter and Total Number of 63 Holes for the Fan Running at 2800 rpm

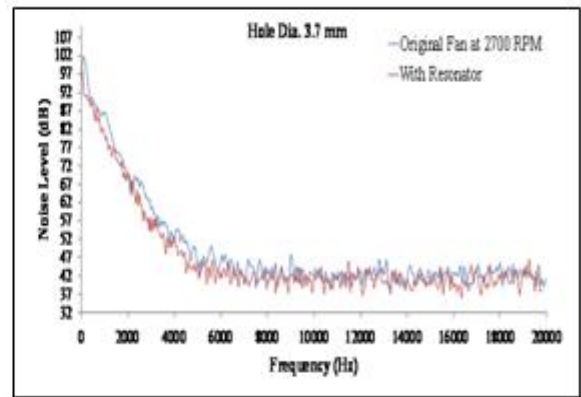

Figure 6 (b): Overall Noise Level and Blade Passing Frequency Component of Resonator 2 of 3.7 mm Hole Diameter and Total Number of 63 Holes for the Fan Running at 2700 rpm

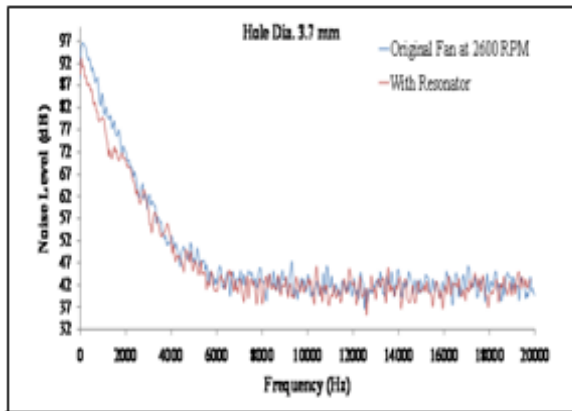

Figure 6 (c): Overall Noise Level and Blade Passing Frequency Component of Resonator 2 of 3.7 mm Hole Diameter and Total Number of 63 Holes for the Fan Running at 2600 rpm

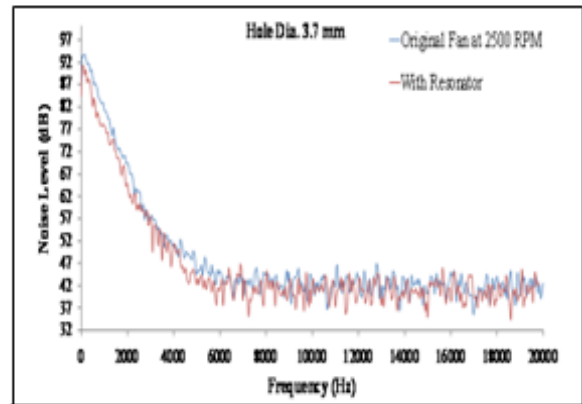

Figure 6 (d): Overall Noise Level and Blade Passing Frequency Component of Resonator 2 of 3.7 mm Hole Diameter and Total Number of 63 Holes for the Fan Running at 2500 rpm

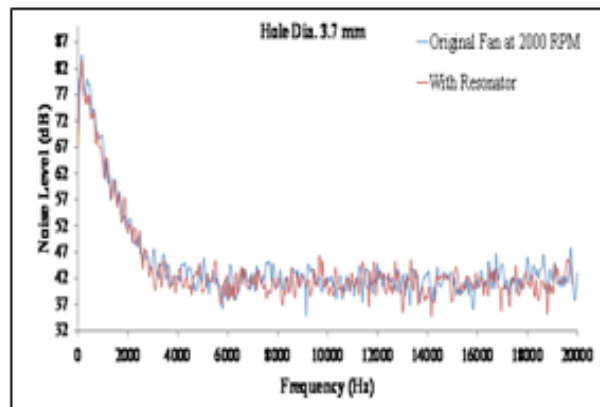

Figure 6 (e): Overall Noise Level and Blade Passing Frequency Component of Resonator 2 of 3.7 mm Hole Diameter and Total Number of 63 Holes for the Fan Running at 2000 rpm

Table 5: Reduction in Overall Noise Level and Blade Passing Frequency Level for the Resonator 2

RPM	% perforation Open Area Proportion	Reduction in Overall Level Noise Level dB (C)	Noise Reduction at Blade Passing Frequency Tone dB (C)
2800	30.79%	7.4	8.9
2700	30.79%	4.2	1.5
2600	30.79%	4.9	5.9
2500	30.79%	3.5	4.2
2000	30.79%	1.7	3.0

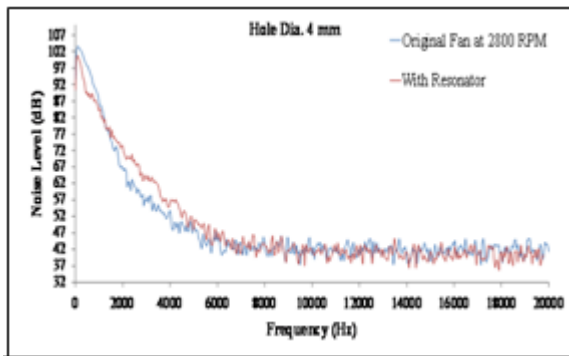

Figure 7 (a): Overall Noise Level and Blade Passing Frequency Component of Resonator 3 of 4.0 mm Hole Diameter and Total Number of 63 Holes for the Fan Running at 2800 rpm

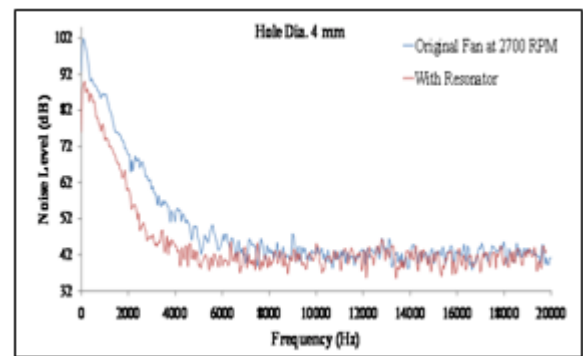

Figure 7 (b): Overall Noise Level and Blade Passing Frequency Component of Resonator 3 of 4.0 mm Hole Diameter and Total Number of 63 Holes for the Fan Running at 2700 rpm

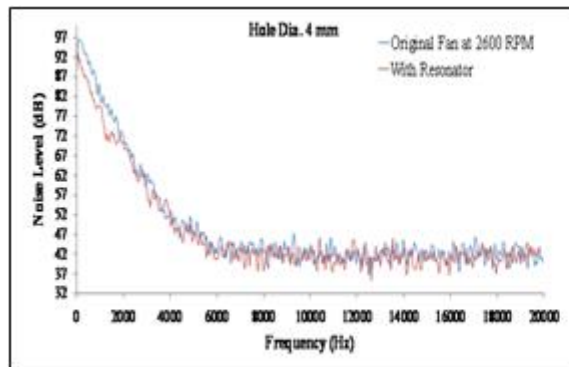

Figure 7 (c): Overall Noise Level and Blade Passing Frequency Component of Resonator 3 of 4.0 mm Hole Diameter and Total Number of 63 Holes for the Fan Running at 2600 rpm

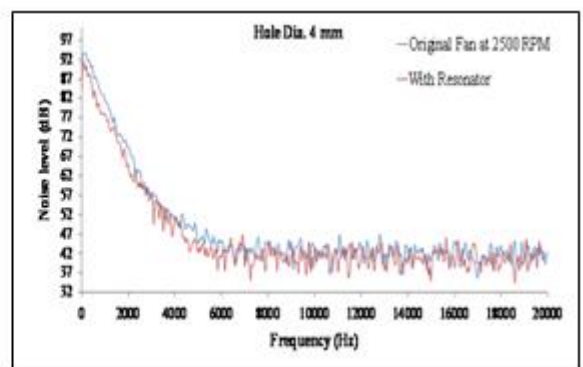

Figure 7 (d): Overall Noise Level and Blade Passing Frequency Component of Resonator 3 of 4.0 mm Hole Diameter and Total Number of 63 Holes for the Fan Running at 2500 rpm

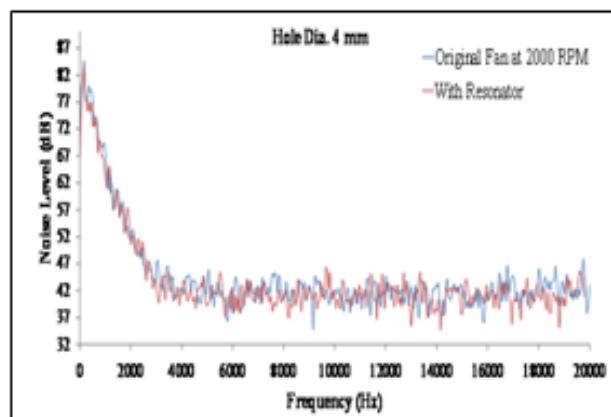

Figure 7 (e): Overall Noise Level and Blade Passing Frequency Component of Resonator 3 of 4.0 mm Hole Diameter and Total Number of 63 Holes for the Fan Running at 2000 rpm

Table 6: Reduction in Overall Noise Level and Blade Passing Frequency Level for the Resonator 3

Rpm	%Perforation Open Area Proportion	Reduction in Overall Noise Level dB (C)	Noise Reduction at Blade Passing Frequency Tone dB (C)
2800	35.98%	8.7	10.5
2700	35.98%	10.1	4.15
2600	35.98%	4.9	5.9
2500	35.98%	3.5	4.2
2000	35.98%	1.7	3.0

Table 7: Maximum Reduction in Overall Noise Level and Blade Passing Frequency Level for the Resonator 1, 2, 3 When the Fan is Running at 2800 Rpm

Resonator	% Perforation Open Area Proportion	Reduction in Overall Noise Level dB (C)	Noise Reduction at Blade Passing Frequency Tone dB (C)
1	27.55%	6.2	8.7
2	30.79%	7.4	8.9
3	35.98%	8.7	10.5

CONCLUSIONS

However with the change in the percentage of open area proportion there is change in the frequency zone in which the maximum reduction takes place. When the percentage perforation open area proportion is small the reduction in the tone amplitude is low, but is spread over a wider frequency range. Conversely, when the percentage perforation open area proportion is large, reduction in the tone amplitude is large, but is spread over a narrow band-width.

Reduction in the blade passing frequency tone depends upon percentage open area combined with the magnitude of the blade passing frequency.

Hence it is necessary to design the quarter wavelength resonator for maximum reduction by trial and error which requires the experimental work with different percentage perforation open area proportion open area proportion for these resonators.

It has been shown experimentally that a $\lambda/4$ resonator mounted at the cut-off a centrifugal fan is a highly efficient and extremely simple means of reducing the blade passage tone. This method can be used for new fan constructions as well as for reducing the noise in existing installations. Since the use of a $\lambda/4$ resonator does not require a change of the geometry of the scroll, the aerodynamic performance of the fan is not affected.

In the existing experiment the fan scroll was modified to mount the resonator for noise reduction. If the resonator was incorporated in the new fan installation at the design stage itself there can be more noise reduction.

In cases of fans with variable speed, a $\lambda/4$ resonator can still be used, provided the length of the resonator is changed in proportion with the fan speed, by moving a plug in the resonator. This would, however, require additional mechanical or electrical equipment for tuning the resonator.

ACKNOWLEDGEMENTS

The authors thank the Principal and Management of Sinhgad College of Engineering, Pune for the continued support and co-operation in carrying out this study.

REFERENCES

1. W. Neise, "Noise Reduction in Centrifugal Fans: A Literature Survey," *Journal of sound and vibration* (1976) 45(3), 375-403
2. G. H. Koopmann, D. J. Fox, W. Neise, "Active Source Cancellation of the Blade Tone Fundamentals and Harmonics in Centrifugal Fans," *Journal of sound and vibration* (1988) 126(2), 209-220
3. W. Neise, "Application of similarity laws to the Blade passage sound of Centrifugal Fans," *Journal of sound vibration* (1975) 43(1), 61-75
4. T. F. W. Embleton, "Experimental Study of Noise Reduction in Centrifugal Blowers," *The Journal of the Acoustical Society of America* Vol. 35, no. 700-705
5. W. Neise, G. H. Koopmann, "Reduction of Centrifugal Fan by Use of Resonators," *Journal of sound and vibration* (1980) 73(2), 297-308
6. G. H. Koopmann, W. Neise, "The Use of Resonators to Silence Centrifugal Blowers," *Journal of sound and vibration* (1982) 82(1), 17-27