

## ANALYZING DRAG REDUCTION USING AERODISK FOR A BLUNT MISSILE NOSE

*Ushaswini Tirunagari*

*Research Scholar, Department of Aerospace Engineering and Applied Mechanics, Shibpur, Howrah, India*

### ABSTRACT

A blunt vehicle flying at supersonic speeds generates a bow shock wave ahead of its nose, which is responsible for the high drag called the wave drag. There have been a number of efforts devoted towards reducing this drag by modifying the flow field ahead of the vehicle's nose. The use of spikes at the blunt nose has been one of the most effective method. This analysis has been carried out to evaluate the feasibility of using the aerodisk as a drag reduction device for blunt cones of a missile flying at supersonic speeds and the resulting drag coefficient values is reported. A numerical analysis is performed using ANSYS Fluent 15 for measuring aerodynamic drag for the blunt nosed cone with and without aerodisk. Further drag is calculated with different L/D ratio (4–14 with an increment of 2) of the aerodisk at zero-degree angle of attack with nominal Mach number of 2.

**KEYWORDS:** Aerodisk, Simplest and the Most Reliable Technique, Measuring Aerodynamic Drag

---

### Article History

**Received: 01 Sep 2019 | Revised: 10 Sep 2019 | Accepted: 20 Sep 2019**

---

### INTRODUCTION

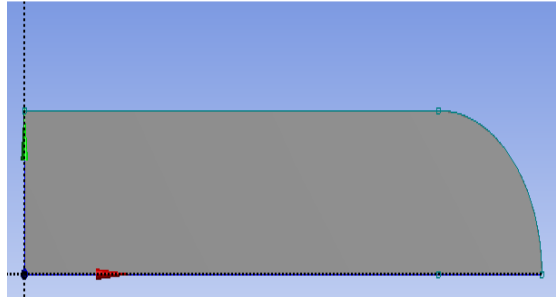
Drag Reduction-Aerodisk Supersonic Blunt Nose-Flow Separation Drag Coefficient Fineness (L/D) Ratio of all the techniques used in drag reduction, spikes are the simplest and the most reliable technique. A spike is simply a slender rod attached to the stagnation point of the vehicle's nose. The spike replaces the strong bow shock with a system of weaker shocks along with creating a zone of recirculating flow ahead of the forebody thus reducing aerodynamic drag. The flow separation resulting from a protruding aerodisk is utilized to achieve substantial drag reduction over the blunt body. The shock stand-off distance is enhanced by the flow separation induced by the aerodisk, thereby minimizing the stagnant flow region, which in turn will reduce the wave drag associated with the bow shock wave. Length of the spike and diameter of the aerodisk can be suitably adjusted to establish a large separation bubble on the face of the blunt cone, which results in shifting the flow re-attachment zone off the body.

### ANALYSIS

The analysis is done on ANSYS Fluent 15.0. Axisymmetric models for the geometries were created and meshed with ANSYS Workbench. Different cases of blunt nosed cone with and without aerodisk, aerodisk with varying length configurations have been examined.

### Blunt Nose Profile Configuration

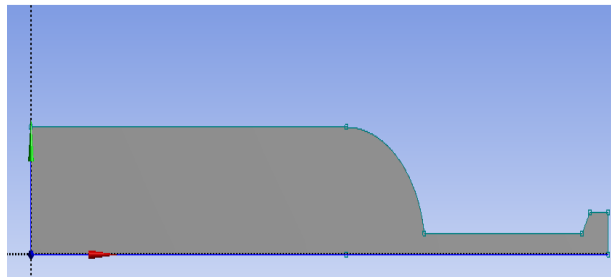
The blunt body is an axis symmetric model; the dimensions of the blunt body are diameter of 30mm. The length to the diameter ratio (L/D) of the body is 2.33. The flow domain is created by creating vertices and joining them as edges which is a square.



**Figure 1: Blunt Nose Profile Configuration.**

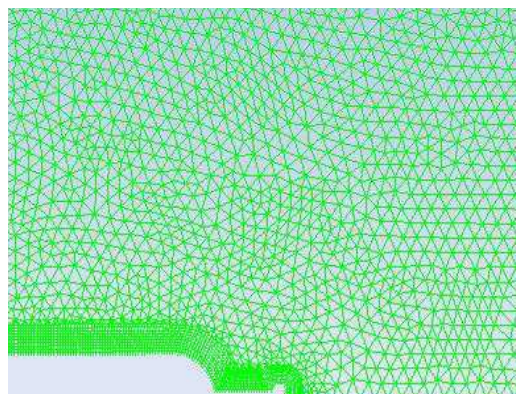
### Blunt Nose with Aerodisk Profile Configuration

The blunt body with aerodisk is an axis symmetric model, the dimensions of the blunt body are diameter of 30mm, and the spike which is mounted at nose of blunt body consist of a Flat triangular disc cap with varying length 20, 30, 40, 50, 60 and 70. The length of the spikes are varies in length to diameter ratio (L/D) such as 4, 6, 8, 10, 12 and 14. The flow domain is created by creating vertices and joining them as edges which is a square.

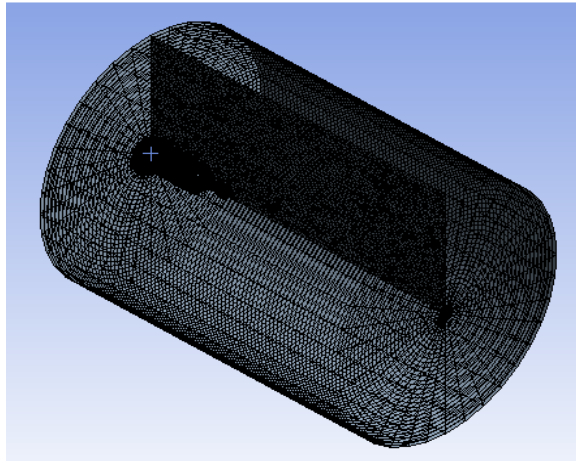


**Figure 2: Blunt Nose with Aerodisk Profile Configuration.**

Boundary layer meshing is mainly used to control mesh density, thereby to control the amount of information available from the computational model in specific regions of interest. It is defined as spacing of mesh node rows in regions immediately adjacent to edges. The domain is designed in such a way, that the flow over the re-entry model is not affected in any case. The face mesh with mapped triangle is used for all computations.



**Figure 3: Boundary layer Meshing.**



**Figure 4: Mapped Mesh of Axisymmetric Model.**

A finite volume method solver in Ansys, a commercial CFD package, is used to simulate the flowfield. The following conditions are used to simulate the models;

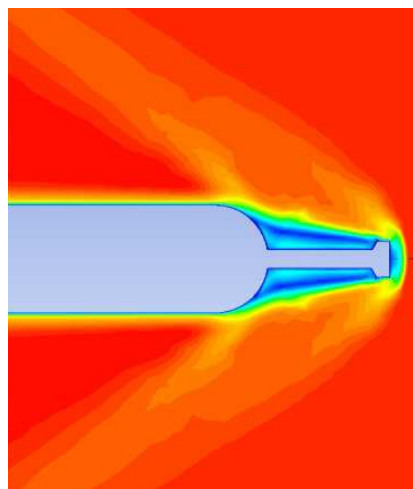
**Table 1**

Solver Type	Pressure based, axisymmetric
Models	Energy (on), SST k- omega
Materials	Ideal gas
Cell zone conditions	Operation pressure= 0
Boundary conditions (inlet)	Pressure far field, P= 1atm, M=2, T= 300K
Boundary conditions (outlet)	Pressure outlet, P= 1atm, T= 300K
Reference values	Area= 706.85 mm <sup>2</sup> , length= 30mm
Solution initialization	Hybrid
Run calculation	Iterations= 500

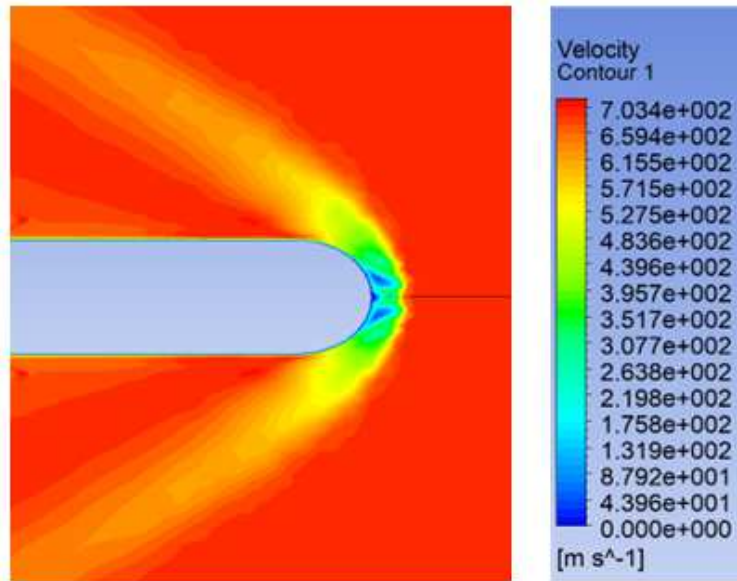
**Results**

**Analysis of the Blunt Nosed Cone with and Without Aerodisk**

Two main computational studies have been carried out in this analysis; with and without aerodisk for a blunt nosed cone. The figures below show the velocity profile of the blunt nose.



**Figure 5: Velocity Profile of a Blunt Nose Configuration.**

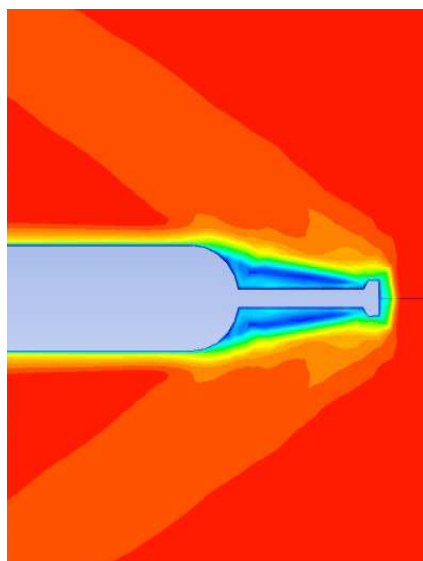


**Figure 6: Velocity Profile of an Aerospike Blunt Nose Configuration.**

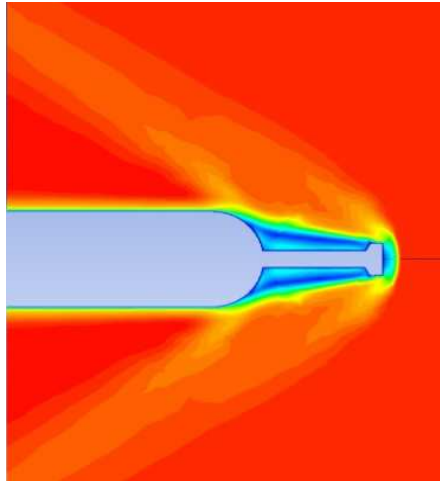
The spike replaces the strong bow shock with a system of weaker shocks along with creating a zone of recirculating flow ahead of the forebody thus reducing aerodynamic drag. The flow separation resulting from a protruding aerodisk is utilized to achieve substantial drag reduction over blunt bodies. The shock stand-off distance is enhanced by the flow separation induced by the aerodisk, thereby minimizing the stagnant flow region, which in turn will reduce the wave drag associated with the bow shock wave.

**Analysis of Blunt Nosed Cone with Different L/D Ratio of the Aerodisk**

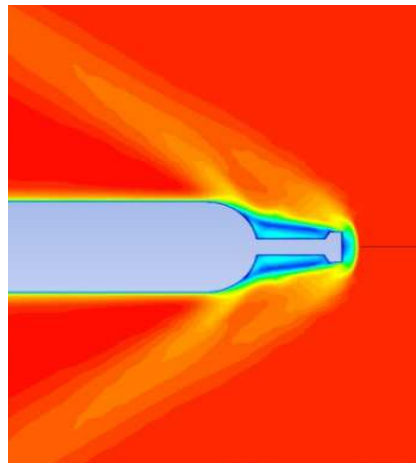
The velocity contours for the flat triangular aero-disk, spike body shows the variation of velocity, along the spike at different L/D ratios such as 4, 6, 8, 10, 12 and 14. The separation zone is found to be function of spike length.



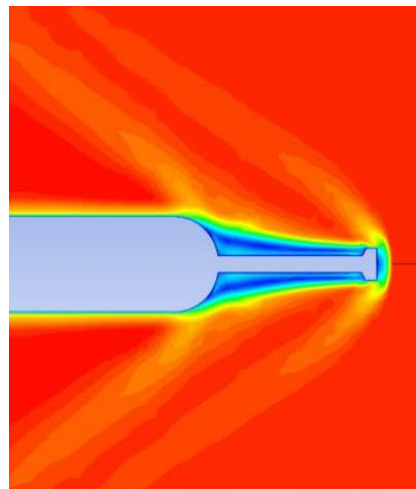
**Figure 6: Velocity Profile of an Aerospike Blunt Nose Configuration.**



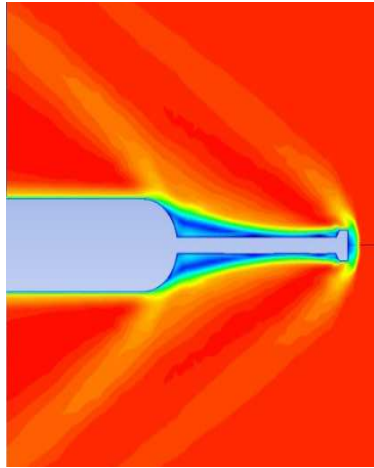
**Figure 8: The Velocity Field Around the Blunt Cone with Flat Aerodisk of L/D 6.**



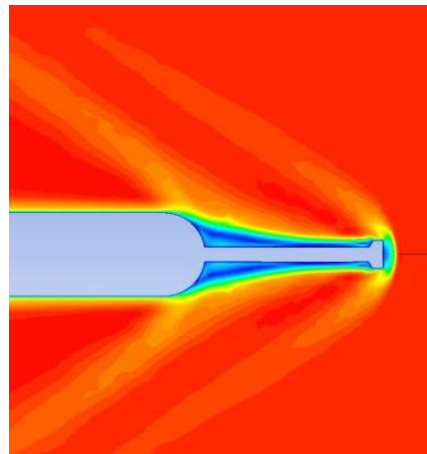
**Figure 9: The Velocity Field Around the Blunt Cone with Flat Aerodisk of L/D 8.**



**Figure 10: The Velocity field Around the Blunt Cone with Flat Aerodisk of L/D 10.**



**Figure 11: The Velocity Field Around the Blunt Cone with Flat Aerodisk of L/D 12.**

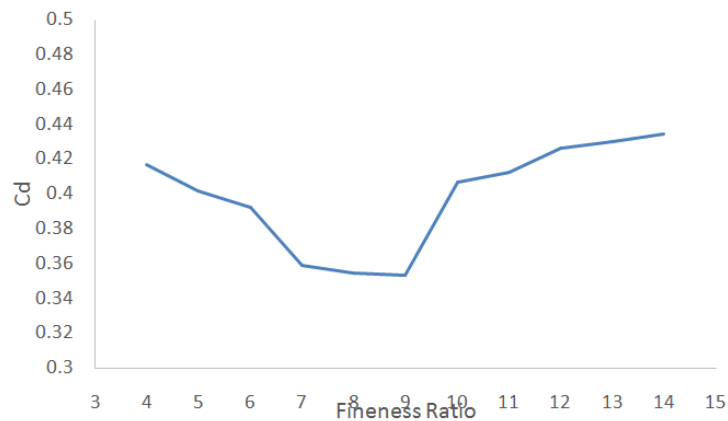


**Figure 12: The Velocity Field Around the Blunt Cone with Flat Aerodisk of L/D 14.**

For smaller length (i.e. for L/D ratio 4, 6 and 8), the flow separates behind the shock wave due to the disk and creates a conical recirculation zone in the vicinity of the stagnation region and the flow reattaches at the blunt body. As the length of the spike increases (i.e. for L/D ratio 10, 12 and 14), the separated flow behind the shock wave again separated on the spike due to its length and further reattaches at the blunt cone. Thus, due to this there is a variation in the drag on the blunt nosed cone.

**Table 2**

L/D Ratio	Cd	% Change in Cd WRT the Lowest Value
4	0.4168	-0.0639
5	0.4014	-0.0485
6	0.3921	-0.0392
7	0.3587	-0.0058
8	0.3545	-0.0016
9	0.3529	0
10	0.4064	-0.0535
11	0.4122	-0.0593
12	0.4261	-0.0732
13	0.4299	-0.0770
14	0.4346	-0.0817



**Figure 1: Variation in the Drag Coefficient with Respect to the Fineness (L/D) Ratio.**

The above graph depicts the variation in the drag coefficient with respect to the fineness (L/D) ratio. From L/D = 4, as the length increases the drag decreases up to L/D = 7 then remains almost constant up to L/D = 9. For L/D > 9, the drag increases due to the separation of the flow over the length of the spike.

## CONCLUSIONS

The experimental results highlight the effectiveness of blunt nosed cone with and without aerodisk and different length of aerodisks as drag reducing devices at supersonic Mach number.

For the blunt cone with forward facing aerodisk, drag reduction of ~ 49.75% has been measured for zero angles of attack at a nominal Mach number of 2.

- The area of low pressure region depends on the aerodisk length which is the main factor for drag reduction.
- For L/D < 7 the drag decreases as length of the spike decreases.
- An aerodisk with 7 < L/D < 9 the drag coefficient almost remains constant and gives the best reduction when comparing with other L/D ratios.
- For L/D > 9, the flow separates on the spike along its length due to which the drag increases.

## REFERENCES

1. Anderson J. D. Jr: *Fundamentals of Aerodynamics*.
2. Jack K. Nielsen: *Missile Aerodynamics*.
3. Wan T, Liu CM (2017): "Drag Reduction Optimization for Hypersonic Blunt Body with Aerospikes", *J Aeronaut Aerospace Eng* 6: 202.
4. Amer G. Miu-Cal (1990): "Spike-Nosed Projectiles: Computations and Dual Flow Modes in Supersonic Flight".
5. R. Kalimuthu and E. Rathakrishnan (2008): "Aerospire for Drag Reduction in Hypersonic Flow", 44<sup>th</sup> AIAA Joint Propulsion Conference & Exhibit.

6. Viren Menezes, S. Saravanan, G. Jagadeesh and K. P. J. Reddy (2002): "Aerodynamic Drag Reduction Using Aerospikes for Large Angle Blunt Cone Flying at Hypersonic Mach Number", 22<sup>nd</sup> AIAA Aerodynamic Measurement Technology and Ground Testing Conference.
7. Gary A. Crowell Sr. (1996): "The Descriptive Geometry of Nose Cones".