

POWER QUALITY IMPROVEMENT USING FUZZY BASED STATCOM

Maddala Saibabu¹ & K. Kiran Kumar²

¹Research Scholar, Department of Electrical and Electronics Engineering, S.R.K.R Engineering College, Bhimavaram, Andhra Pradesh, India

²Assistant Professor, Department of Electrical and Electronics Engineering, S.R.K.R Engineering College, Bhimavaram, Andhra Pradesh, India

ABSTRACT

This paper proposes application of fuzzy logic controller to regulate 12-pulse statcom controller for mitigate voltage flickers and current harmonics. Selective interharmonic compensation is introduced to improve Statcom performance for Light Flicker (LF) compensation caused by implementation of arc furnace as load. This makes it possible to compensate only the interharmonics in a proper band around the fundamental frequency that mainly affects LF. The reference signal required for 12-pulse converter is regulated with fuzzy controller. The relevant effect is a reduction of the compensation power needed to obtain mitigations of LF from the source to be compensated. This proposed system is to be implemented in Matlab/Simulink under different control techniques as a comparative analysis.

KEYWORDS: Light Flicker, Fuzzy Logic, Arc Furnace, 12-pulse Statcom, SIF and Harmonic Distortion

Article History

Received: 18 Dec 2020 | Revised: 22 Dec 2020 | Accepted: 26 Dec 2020

INTRODUCTION

Even a few years back, the main concern of consumers of electricity was the reliability of supply. Here we define reliability as the continuity of electric supply. Even though the power generation in most advanced countries is fairly reliable, the distribution is not always so. Voltage flickers are caused by arc discharge lamps, arc furnaces, starting of large motors, arc welding machines etc. Voltage flickers are frequent variations in voltage that can cause the light intensity from incandescent lamps to vary. This variation is perceived as disturbing by human observers, particularly in the range of 3 to 15 times per second.

The concept of power quality describes the quality of the supplier Voltage in relation to the transient breaks, falling voltage, harmonics and voltage flicker. Voltage Flicker is the disturbance of lightning induced by voltage fluctuations. Very small variations are enough to induce lightning disturbance for human eye for a standard 230V, 60W coiled-coil filament lamp. The disturbance becomes perceptible for voltage variation frequency of 10 Hz and relative magnitude of 0.26 %. Huge non-linear industrial loads such as the electrical arc furnaces, pumps, welding machines, rolling mills and others are known as flicker generators. In this respect, the quality of supplied voltage is significantly reduced in an electrical power system and the oscillation of supplied voltage appears to be a major problem.

Electric arc furnace, the main generator of voltage flicker, behaves in the form of a constant reactance and a variable resistance. The transformer-reactance system is modelled as a lumped reactance, a furnace reactance and a variable resistance which models the arc. Connecting this type of load to the network produces voltage variation at the common point of supply to other consumers.

The Power-frequency disturbances are defined as events related to the power frequency caused due to switching operations. As soon as the event producing the disturbance is cleared these disturbances get diminished with time. This helps the power system to come back to its normal operating condition. The acknowledgment of Low-frequency disturbances is very easy. The voltage sag can be recognized by observing dimming of lights and voltage well is observed when lights shine brighter because of rise in the voltage. The detection and measurement of these low-frequency disturbances is easy but restitution is monotonous work. On the other hand both detection and reparation of Transients is less complicated than low-frequency events. There are various measures available to deal with low frequency disturbances like Isolation transformers, Voltage regulators, Static Uninterruptible Power Sources, Rotary UPS. However, these methods have limitation for removal of low frequency variations.

In addition to the conventional procedures for the compensators, the active filters are used for the voltage flickers mitigation as well. Furthermore, the mitigating devices based on Static VAR Compensator (SVC) such as Thyristor Switched Capacitor TSC, Thyristor Controlled Reactor (TCR), and FCTCR, are the most frequently used devices for reduction in the voltage flicking.

The Statcom is typically based on a Voltage-Source Inverter (VSI) with a capacitor on the DC side. The converter is shunt connected to the network through an inductive interface. The compensator performs voltage regulation by acting as a controllable source of reactive power. Modern Statcoms are also able to compensate small amounts of active power thanks to their ability to perform active harmonic filtering. The performances of the Statcoms for LF mitigation are essentially due to the control algorithm used for the extraction of reference current components. Therefore, many control algorithms have been proposed in the literature. Among these, the most commonly used are based i) on the Instantaneous Reactive Power theory and ii) Synchronous Reference Frame theory.

A 6-pulse voltage-source converter STATCOM was used to compensate for the voltage flicker. With respect to the harmonic problem in this stage, a 12-pulse voltage-source converter STATCOM was designed to isolate load harmonics and mitigate the propagation of voltage flicker to the system in the next stage. The obtained results clearly confirmed the efficiency of the 12-pulse STATCOM to complete the voltage flicker mitigation

In order to suppress the harmonic components in output current, a literature presents a minimal harmonic controller. It uses a controller with fixed modulation index and variable dc capacitor voltage reference to minimize the voltage and current harmonics. However, the determination of the voltage and current regulator parameters is complicated, and it can't optimize the specified harmonic components. In addition, there's another literature which presents an optimization method based on the generalized coordinate transformation harmonic detection. The selective harmonic components extracted by the generalized $d_k - q_k$ coordinate transform are fed forward into the control loop. Although it uses a series of adaptive adjustment methods for the feed-forward gain, the compensation precision, system stability and practical applicability are still not very well.

PROPOSED SYSTEM

The main circuit of the three-phase three-wire STATCOM with an LCL filter is shown in Figure 1, and it's a three-phase two-level voltage source inverter. Here, the terms v_{sa} , v_{sb} and v_{sc} represent the three-phase grid voltage, u_{ia} , u_{ib} and u_{ic} represent the STATCOM three-phase output voltage, i_{1a} , i_{1b} and i_{1c} represent the three-phase inductor current of the inverter side, i_{2a} , i_{2b} and i_{2c} represent the three-phase inductor current of the grid side, u_{dc} represents the DC bus voltage. In addition, R_d is the damping resistance in the filter capacitor branch, and it is used to reduce the gain of the LCL filter at the resonant frequency, so as to prevent the occurrence of oscillation at the resonant frequency, which may cause the system instability.

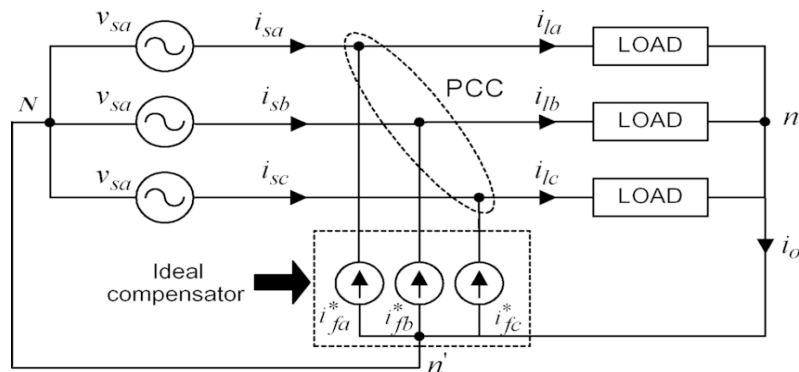

Figure 1: Proposed System of Three Phase with STATCOM.

MODELLING OF STATCOM

A STATCOM (Static Compensator), which is schematically depicted in Figure-1, consists of a two-level Voltage Source Converter (VSC), a dc energy storage device, a coupling transformer connected in shunt to the distribution network through a coupling transformer. The VSC converts the dc voltage across the storage device into a set of three-phase ac output voltages. These voltages are in phase and coupled with the ac system through the reactance of the coupling transformer. Suitable adjustment of the phase and magnitude of the STATCOM output voltages allows effective control of active and reactive power exchanges between the STATCOM and the ac system. Such configuration allows the device to absorb or generate controllable active and reactive power.

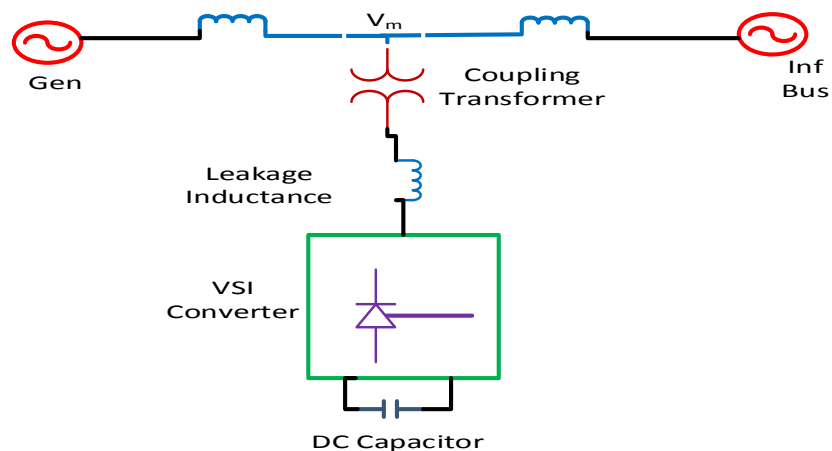

Figure 2: Schematic Diagram of a STATCOM.

The VSC Connected in Shunt with the Ac System Provides A Multifunctional Topology Which can be Used for Up To Three Quite Distinct Purposes:

- Voltage regulation and compensation of reactive power;
- Correction of power factor
- Elimination of current harmonics.

The six-pulse STATCOM is the simplest arrangement used in this kind of devices; in high power applications it does not offer a good performance, due to the high harmonic content. Combining two six-pulse converters, a better performance is obtained. This new configuration is called twelve-pulse STATCOM. The twelve-pulse circuit is the lowest practical pulse-numbered circuit for power system application to achieve a satisfactory harmonic behaviour.

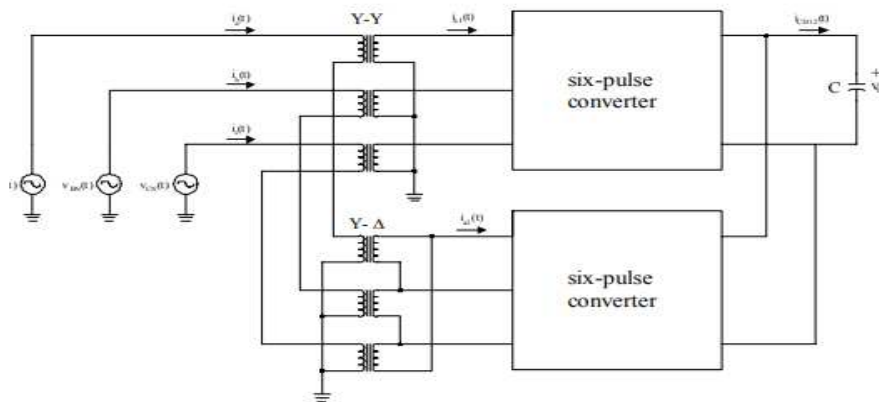

Figure 3: 12-Pulse VSI-STATCOM.

When switching functions are approximated by their fundamental frequency components neglecting harmonics, STATCOM can be modelled by transforming the three-phase voltages and currents to D-Q variables using Park’s transformation [10]. The STATCOM can be represented functionally, as shown in Figure 3. The magnitude control of converter output voltage is the function of DC voltage for type-2 converters. The converter output voltage can be represented in the D-Q frame of reference as

$$V_s^i = \sqrt{V_{sD}^i{}^2 + V_{sQ}^i{}^2},$$

$$V_{sD}^i = kV_{dc} \sin(\theta_s + \alpha),$$

$$V_{sQ}^i = kV_{dc} \cos(\theta_s + \alpha),$$

Where ‘ θ_s ’ is the phase angle of bus voltage. α is the angle by which the fundamental component of converter output voltage leads the STATCOM bus voltage.

Concerning the switching strategy used to drive the VSI of the Statcom, a hysteresis control was selected because of its unconditioned stability, very fast response, and good accuracy in spite of the variable switching frequency, which inhibits the use of interleaved techniques. The DC side voltage of the VSI is modelled as an ideal DC voltage source (V_{dc}), which guarantees the necessary active power for CA2 to compensate the AC component of i_d . The controllable load makes it possible to generate all the desired fundamental and inter harmonic currents.

The control algorithms based on the Park transform for Stat coms are here reformulated to show the presence of inter harmonic components to focus on LF mitigation. Reference is made to the classical block scheme of Figure 4. Let us consider three-phase instantaneous alternate currents affected by harmonic and inter harmonic distortion. Introducing the concept of the Fourier fundamental angular frequency ωF , which is the greatest common divisor of all the frequency components contained in the signal, all of the $N = \omega MAX / \omega F$ spectral components of the signals are harmonics of ωF . Separating the system fundamental angular frequency component, harmonics, and inter harmonics, it is possible to write the following:

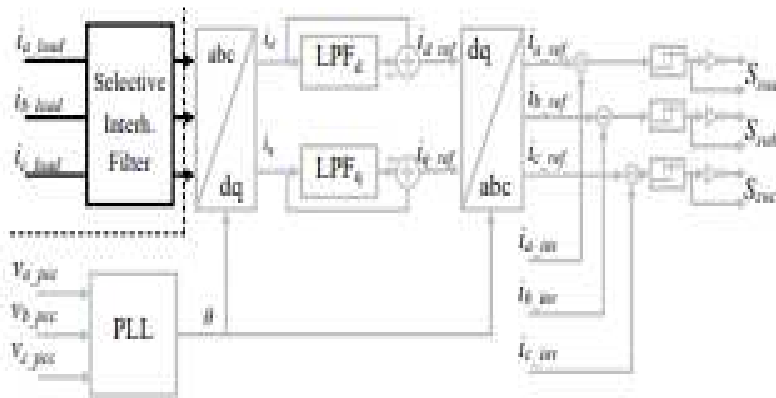

Figure 4: Control Structure for STATCOM Controller.

$$\begin{cases} i_a(t) = i_a^{h1}(t) + \sum_{h \in H} i_a^h(t) + \sum_{ih \in IH} i_a^{ih}(t), \\ i_b(t) = i_b^{h1}(t) + \sum_{h \in H} i_b^h(t) + \sum_{ih \in IH} i_b^{ih}(t), \\ i_c(t) = i_c^{h1}(t) + \sum_{h \in H} i_c^h(t) + \sum_{ih \in IH} i_c^{ih}(t), \end{cases}$$

Where $h1 = \omega 1 / \omega F$ is the harmonic order of the system fundamental angular frequency, and H and IH are subsets containing the harmonic orders of ωF corresponding to integer h (i.e., harmonics) and not integer ih multiples (i.e., interharmonics) of $\omega 1$, respectively

$$\begin{cases} i_p^{h1}(t) = I_p^{h1} \sin(h1 \cdot \omega_F t + \varphi_p^{h1}), \\ i_p^h(t) = I_p^h \sin(h \cdot \omega_F t + \varphi_p^h), \quad \forall h \in H \\ i_p^{ih}(t) = I_p^{ih} \sin(ih \cdot \omega_F t + \varphi_p^{ih}) \quad \forall ih \in IH \end{cases}$$

The three-phase currents are converted into equivalent direct and quadrature axis component currents (i_d, i_q) using Park's transformation matrix:

$$\begin{bmatrix} i_d(t) \\ i_q(t) \end{bmatrix} = \frac{2}{3} \begin{bmatrix} \sin \theta & \sin\left(\theta - \frac{2\pi}{3}\right) & \sin\left(\theta + \frac{2\pi}{3}\right) \\ \cos \theta & \cos\left(\theta - \frac{2\pi}{3}\right) & \cos\left(\theta + \frac{2\pi}{3}\right) \end{bmatrix} \begin{bmatrix} i_a(t) \\ i_b(t) \\ i_c(t) \end{bmatrix},$$

A second-order filter was selected based on the experiments and analyses performed. The transfer function used for the filter SIF(s) is

$$SIF(s) = K_B \cdot \frac{s^2 / \omega_{B1}^2}{s^2 + 2\zeta_{\omega_B} \omega_{B1} + \omega_{B1}^2} \cdot \frac{\omega_{B2}^2}{s^2 + 2\zeta_{\omega_B} \omega_{B2} + \omega_{B2}^2}$$

FUZZY LOGIC CONTROLLER

In the previous section, control strategy based on PI controller is discussed. But in case of PI controller, it has high settling time and has large steady state error. In order to rectify this problem, this paper proposes the application of a fuzzy controller shown in Figure 5. Generally, the FLC is one of the most important software based technique in adaptive methods. As compared with previous controllers, the FLC has low settling time, low steady state errors.

Figure 5 shows in this paper, the membership function is considered as a type in triangular membership function and method for defuzzification is considered as centroid. The input variables such as error and error rate are expressed in terms of fuzzy set with the linguistic terms VN, N, Z, P, and Pin this type of mamdani fuzzy inference system the linguistic terms are expressed using triangular membership functions. In this paper, single input and single output fuzzy inference system is considered. The number of linguistic variables for input and output is assumed as 3. The numbers of rules are formed as 9. This input is related with the logical operator AND/OR operators. AND logic gives the output as minimum value of the input and OR logic produces the output as maximum value of input.

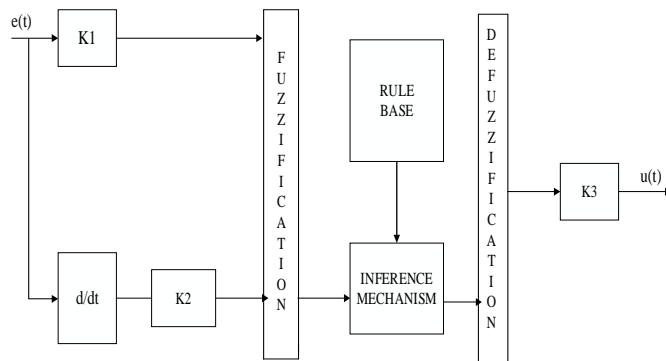

Figure 5: Basic Structure of Fuzzy Logic Controller.

SIMULATION DIAGRAM AND RESULTS

The experimental case study was performed using measurements taken in a MATLAB/Simulink, where the main power quality problem was an excessive light flicker level caused mainly by an electric arc furnace and a ladle furnace installed in the factory. To mitigate he flickers in voltage and current harmonics, the proposed system is tested under differ cases i.e. 1) with STATCOM and SIF based STATCOM, 2) 12-pulse fuzzy based STATCOM controller. Figure 6, shows a simulation diagram of the proposed system in 12-pulse converter.

The simulation result for source current and voltage under with and without controller is shown in Figure 7 & Figure 10.

Due to the presence of Arc furnace as load, flickers occur in system voltage. The effected voltage flickers at source side and its current is shown in figure 7 as without application of controller and Figure 8 as STATCOM-SIF controller. The source voltage and current for Fuzzy based controller is shown on Figure 9.

Comparison of Table 1, the FFT of proposed converter is better with application of fuzzy based 12-pulse STATCOM controller.

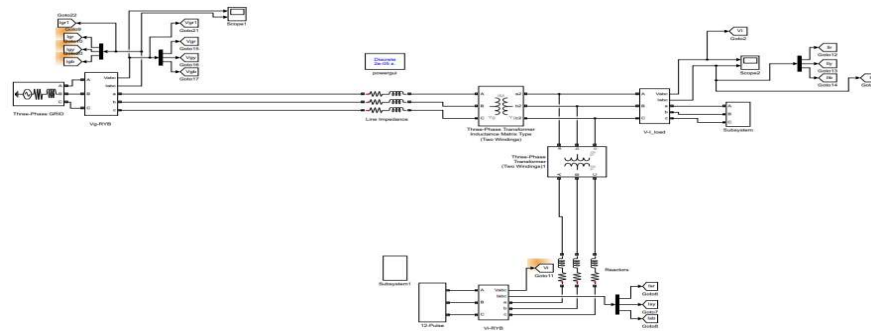

Figure 6: Simulation Diagram for Proposed 12-Pulse STATCOM Converter.

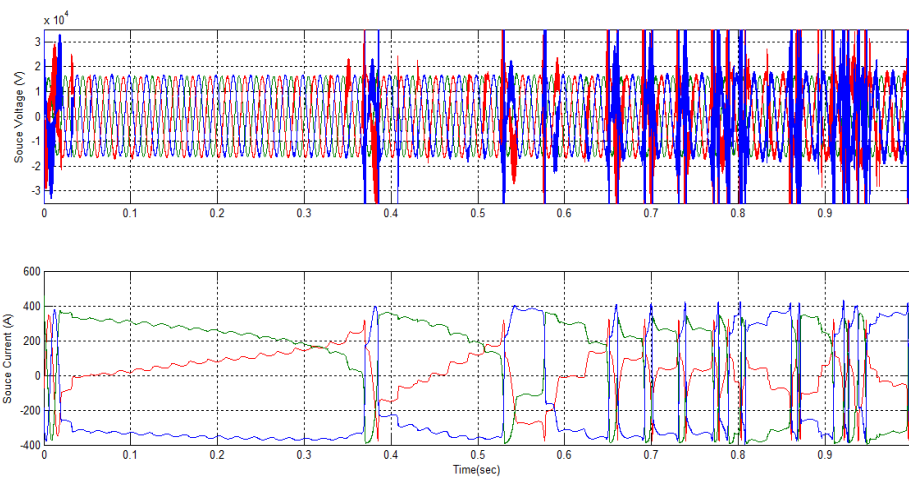

Figure 7: Source Voltage & Source Current Waveform without Controller.

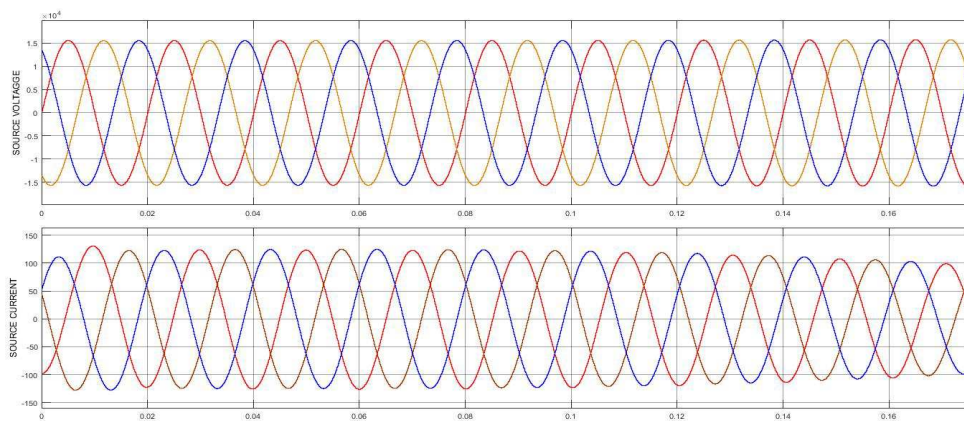

Figure 8: Source Voltage & Source Current Waveform with STATCOM Controller.

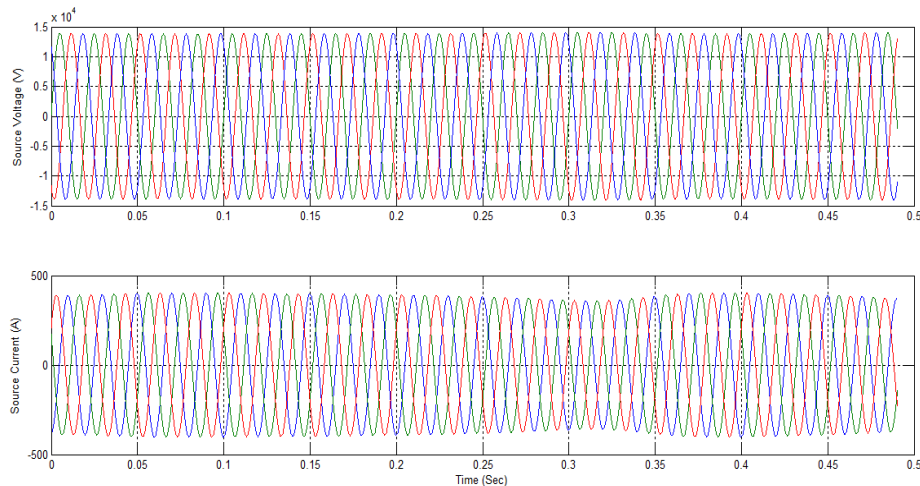

Figure 9: Source Voltage & Source Current Waveform with Fuzzy Based 12-Pulse STATCOM Controller.

Table-1: FFT Analysis for Source Current

S. No	Controller	THD (%)
1	Without Any controller	56.23
2	STATCOM Controller	6.85
3	SIF-STATCOM	5.46
4	12-Pulse STATCOM	1.52
5	Fuzzy based 12-pulse STATCOM	0.74

CONCLUSIONS

A Fuzzy based Selective interharmonic compensation was introduced to improve the performances of Statcoms for flicker mitigation. The proposed approach modifies classical control algorithms based on the Park transform typically adopted for Statcom control. An improvement was obtained by introducing a selective interharmonic filter into the classical control scheme. This makes it possible to compensate only the interharmonics in a proper band around the fundamental frequency, which mainly affects LF. The relevant effect is a reduction in the compensation power needed to mitigate the LF emissions from the source to be compensated (e.g. arc furnaces) to levels compatible with standards. Simulation case studies are implemented for Fuzzy and SIF based Statcom controller to mitigate inter-harmonics. From these analyses, it confirmed the usefulness of the proposed fuzzy based controller gives better LF mitigation as compared with conventional controllers.

REFERENCES

1. L. Feola and R. Langella, "Selective Interharmonic Compensation to Improve Statcom Performance for Light Flicker Mitigation", 0885-8977 (c) 2018 IEEE.
2. A.T. Johns, A. Ter-Gazarian and D.F. Warne, "Flexible AC transmission systems (FACTS)," IEE Power Energy Series, the Institute of Electrical Engineers, London, UK, 1999.
3. V.K. Sood, "HVDC and FACTS controllers: applications of static converters in power systems," Kluwer Academic Publishers, USA, 2004.
4. Zhengping Xi and S. Bhattacharya, "Magnetic Saturation in Transformers used for a 48-pulse Voltage-Source Converter based STATCOM under Line to Line System Faults," in. Prof of IEEE Power Electronics Specialists Conference, 2007, PESC 2007, IEEE, 17-21 June 2007, pp.2450–2456.

5. B. Singh and R. Saha, "A New 24-Pulse STATCOM for Voltage Regulation," *International Conference on Power Electron. Drives and Energy Systems*, 2006. PEDES '06, 12-15 Dec. 06, pp. 1-5.
6. J. Arrillaga, Y. H. Liu and N. R. Waston, "Flexible Power Transmission, The HVDC Options," *John Wiley & Sons, Ltd, Chichester, UK*, 2007.
7. M. Hagiwara, H. Fujita and H. Akagi, "Performance of a Self Commutated BTB HVDC Link System under a Single-Line to-Ground Fault Condition," *IEEE Trans. on Power Electronics*, vol. 18, no. 1, pp.278-285, Jan-2003.
8. M. Hagiwara and Hirofumi Akagi, "An Approach to Regulating the DC Link Voltage of a Voltage-Source BTB System During Power Line Faults," *IEEE Trans. on Industry Applications*, vol. 41, no. 5, pp. 1263- 1271, Sep/Oct-2005.
9. *IEEE Standard 519-1992, IEEE Recommended Practices and Requirements for Harmonic Control in Electrical Power Systems*, IEEE Inc., New York, 1992.
10. Xi Zhengping and S. Bhattacharya, "Magnetic Saturation in Transformers used for a 48-pulse Voltage-Source Converter based STATCOM under Line to Line System Faults", *Prof of IEEE Power Electronics Specialists Conference 2007 PESC 2007*, pp. 2450-2456, 17-21 June 2007.
11. J. Arrillaga, Y. H. Liu and N. R. Waston, "Flexible Power Transmission The HVDC Options" in, *Chichester, UK: John Wiley & Sons, Ltd*, 2007.
12. J.L. Agero, F. Issouribehere and P.E. Battaiotto, "STATCOM Modeling for Mitigation of Voltage Fluctuations caused by Electric Arc Furnaces", *IEEE PES General Meeting*, 2006.
13. V. B. Virulkar and M. V. Aware, "Voltage Flicker Mitigation Using STATCOM and ESS", *Second International Conference on Power Electronics, Machines and Drives, PEMD2004*, vol. 1, pp. 175-180.
14. B. Blazic and I. Papic, "Analysis of Flicker Mitigation in a Utility Distribution Network", *EUROCON2003*, vol. 2, pp. 292-296.
15. G.F. Reed, J.E. Greaf, T. Matsumoto, Y. Yonehata, M. Takeda, T. Aritsuka, Y. Hamasaki, F. Ojima, A.P. Sidell, R.E. Chervus, C.K. Nebecker, "Application of a 5 MVA, 4.16 kV D-STATCOM System for Voltage Flicker Compensation at Seattle Iron & Metals", *IEEE PES Summer Meeting*, 2000, vol. 3, pp. 1605-1611.
16. R. Grunbaum, T. Gustafsson, J. Hasler, M. Osada, J. Rasmussen, K. Thorburn, "STATCOM for Flicker Suppression from a Steel Plant Connected to a Weak 66 kV Grid", *International Power Electronics Conference, IPEC2010*, pp. 1773-1779.
17. Colin Schauder, "STATCOM for Compensation of Large Electric Arc Furnace Installations", *IEEE Power Engineering Society Summer Meeting*, 1999, vol. 2, pp. 1109-1112.

